

CVG45 LSR Cold Shut off Nozzle

CVG45 LSR is a cold shut-off nozzle to be installed on a mold that is expressly engineered for the molding of liquid silicone rubber (LSR). This nozzle is characterized by a very large and unobstructed injection channel and by a high efficiency cooling circuit that allow to minimize scraps of material. These features combined with its extremely simple construction makes it the ideal solution for the molding of LSR.



CVG45 LSR Cold Shut off Nozzle

- Cycle time optimization**
the remarkable efficiency of the cooling system allows to reduce the risk of LSR vulcanization inside the nozzle
- Reliability**
a specifically engineered bush made of rubber material prevents material leakages into the control piston
- Customization**
Injection point size can be customized from 0,8 to 3,5 mm
- Low pressure losses**
the large free and unobstructed injection channel reduces pressure losses to the minimum with great advantages in the filling stage.
- Easy to clean**
the closing pin during the injection phase slides completely out of the flow: no material stagnation and faster and easier cleaning
- Stainless steel compact construction**

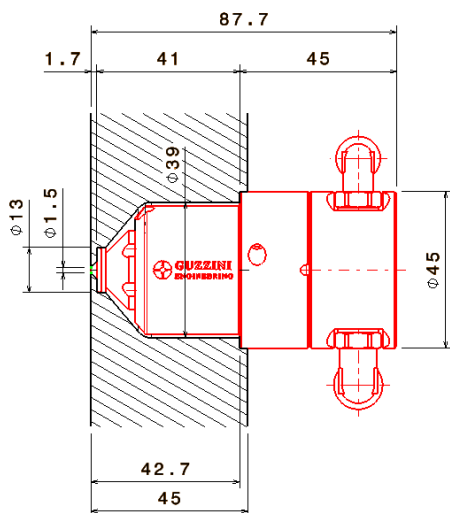

Main Features	
Temperature range C°	-10 +70
Max Injection rate. Cm ³ / s	350
Max Injection Pressure. Bars	2500
Standard Injection Gate ϕ mm	1,5 (Max 3,5)
Actuation	Pne. (8 Bars)